

변경 사항			
기호	변경 내용	날짜	수정 인
△			
△			

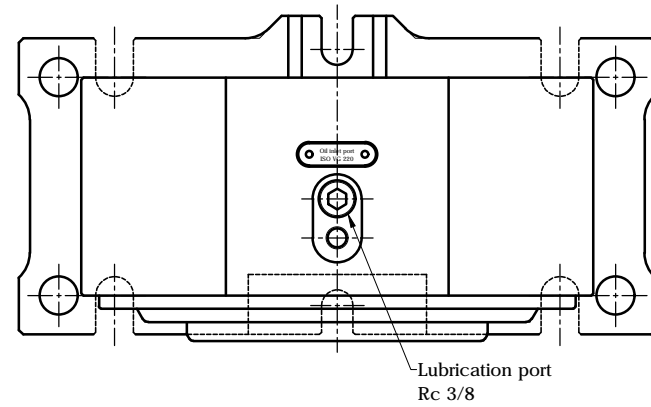

별도 포장

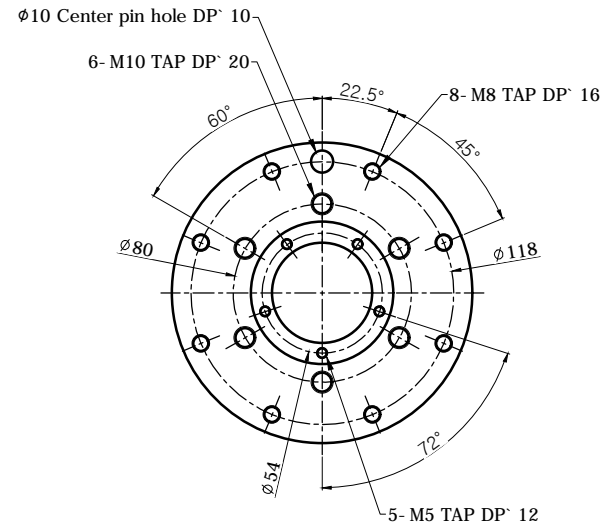
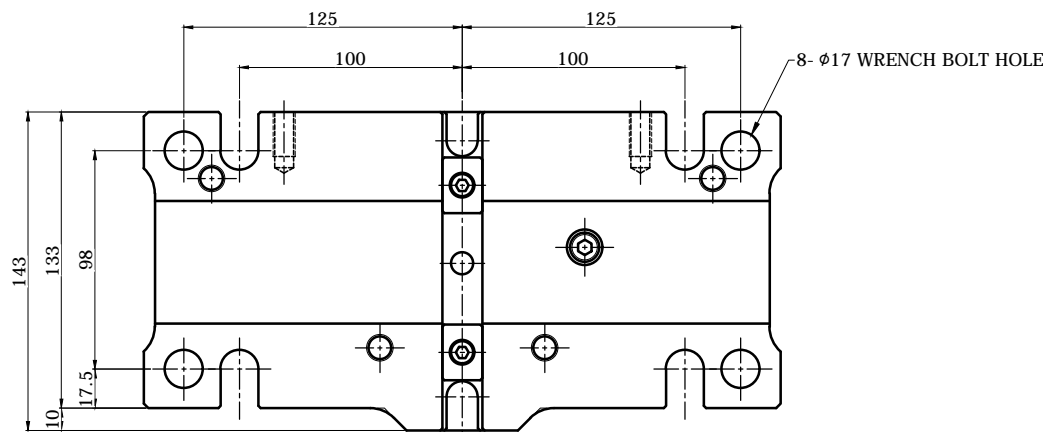
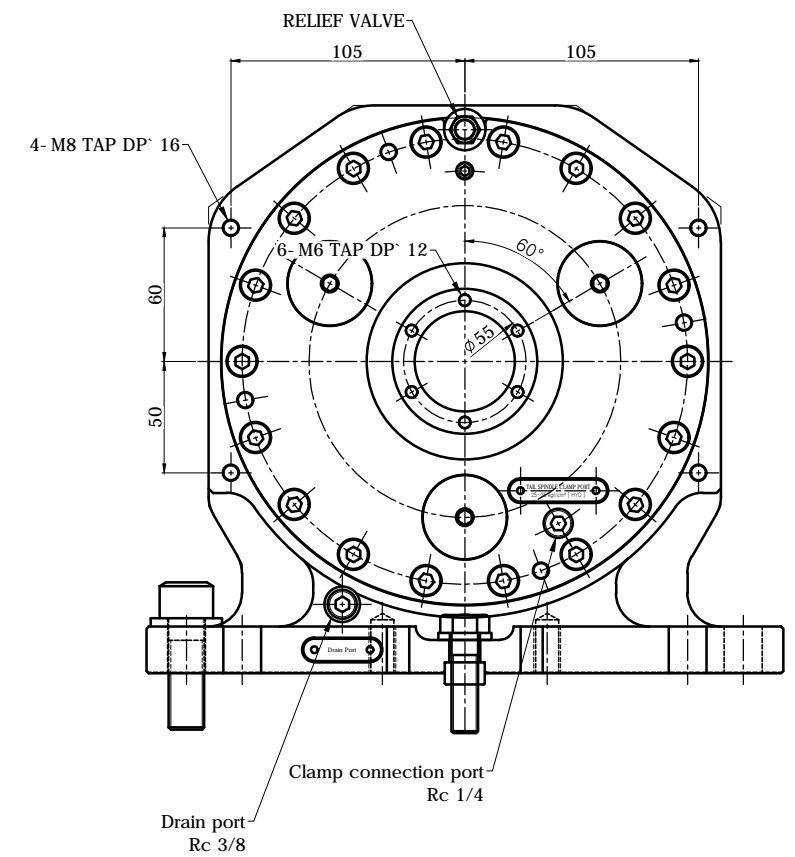
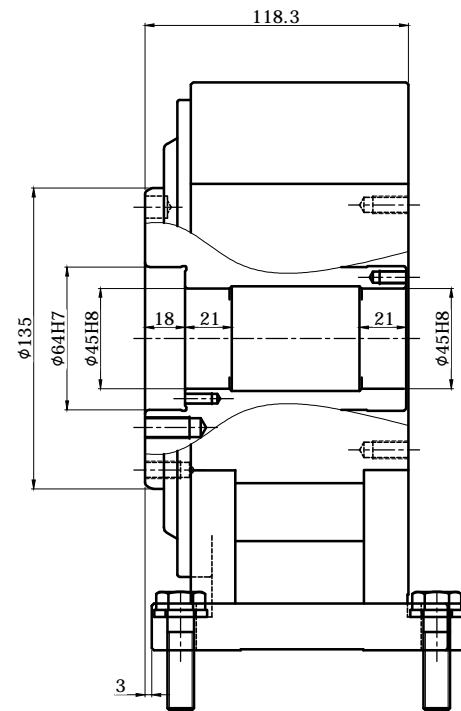
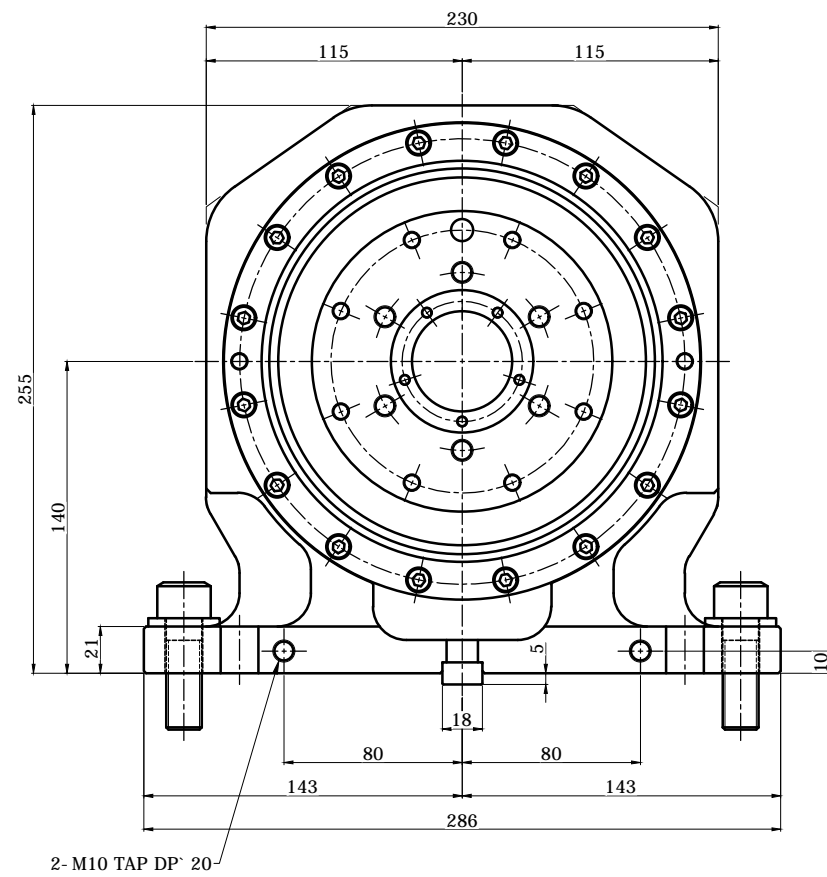
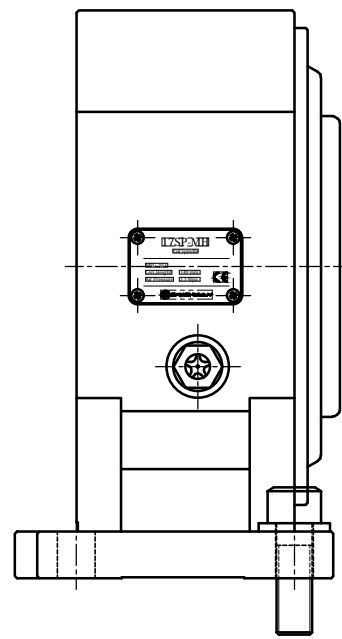
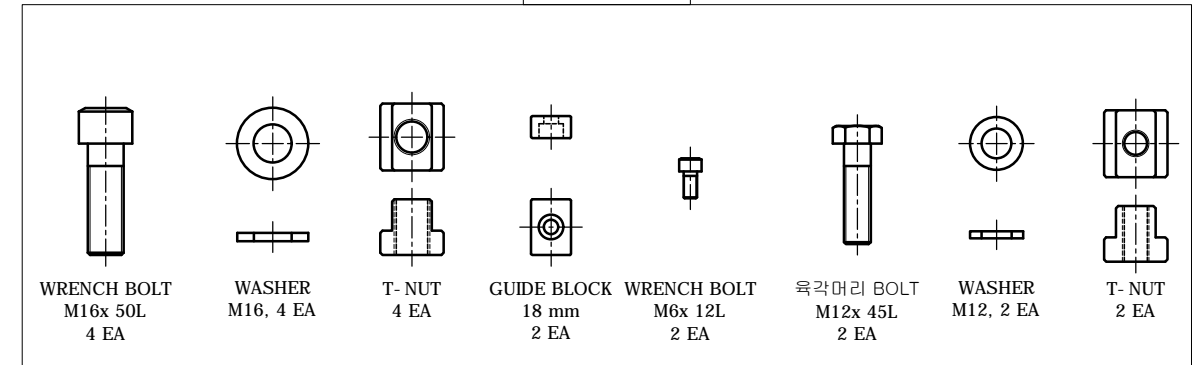

SPECIFICATIONS	
Center Height [mm]	140
Thru Hole Diameter [mm]	φ40
Clamp Method	Hydraulic
Max Pressure	25~35 kgf/cm ²
Clamp Torque [N.m]	480
Weight [kg]	26

TITLE	Tail Spindle (Hydraulic)	PART NAME	외 형 도
DRG. NO.	17SP-MH-00	USER	-
CODE NO.	-	DEPARTMENT	Research & Development
DATE	2021. 05. 01		
SCALE	1 : 1	Approved	Checked
		Designed	

